

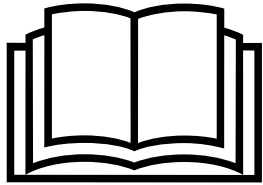

Operators Instruction Manual



8" TG8 Grinder

Floor Grinder and Floor Grinder/Polisher



P/N and Power

G00046 Electric 2 HP with Grinding Plate
G00057 Electric 2 HP with TEQ-Lok Plate
G00060 Electric 2 HP variable speed with Grinding Plate
G00047 Electric 2 HP variable speed with TEQ-Lok Plate
G00048 Gas 5.5 HP Honda with Grinding Plate
G00058 Gas 5.5 HP Honda with TEQ-Lok Plate
G00072 Gas 5.5 HP Subaru with Grinding Plate
G00073 Gas 5.5 HP Subaru with TEQ-Lok Plate

Serial Number

Manual No. 161239 Rev 2/14
©2012, Printed in USA

DITEQ Corporation
9876 Pflumm Road
Lenexa, KS 66215
Phone: 816-246-5515
Fax: 816-246-1530
www.DITEQ.com



Completely read and fully understand the contents of this Operators Instruction Manual before attempting to operate this equipment. Death or serious injury could result from the improper use of this equipment.



Safety Message Alert Symbols

Some of the safety message in the manual are emphasized with a graphic safety message alert symbol of DANGER, WARNING or CAUTION.



Indicates an imminent hazard which, if not avoided, will result in death or serious injury



Indicates an imminent hazard which, if not avoided, can result in death or serious injury



Indicates hazards which, if not avoided, could result in serious injury and or damage to the equipment

Table of Contents

<i>Section</i>	<i>Page(s)</i>
Safety Symbols	2
General Instructions	3
Accessories	4-8
Grinding, Polishing	8-10
Hoisting and Lifting	10
Info specific to Power option	11-12
Maintenance Instructions	13-15
Parts List	16-22
Wiring Diagram	23
Warranty	BC

Hazard Symbols

Additional information as to the nature of the hazard is provided by the following hazards symbols which appear throughout the manual in conjunction with safety message alert symbols



Read the Operators Instruction Manual



Wear boots with non-slip soles to prevent slipping

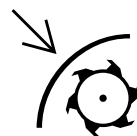

Keep Guards in place during operation



Safety Glasses are required to protect eyes from flying debris.



Operation of this machine produces lethal gasses, dust and fumes.



Properly lockout machine power source during maintenance and cleaning.



Use the appropriate Respirator for the dust exposure.



Explosion Hazard



Burn Hazard and hot surface.



Wear the appropriate Hearing protection for the sound pressure levels generated



ALERT



Pinch Point from belt and pulley.



Wear the appropriate head protection



Electrical shock and electrocution hazard



Properly dispose of the dust generated by the operation of this machine.

General Instructions

For your safety and the safety of others around you, you must only operate this machine in the way it was intended.

Before operation the machine must be inspected by the operator for damaged components or loose hardware to be certain the machine is in good working order.

Before operation the job site must be inspected by the operator to identify and resolve potential hazards. The work area needs to be defined and appropriately marked.

The operator must be physically able to handle the bulk weight and power of the equipment. The operator must not be in an impaired mental state so they can exercise good judgement to maintain a safe working environment.

This floor grinder (or grinder/polisher) is a 'one person' machine. All others must keep a safe distance from the machine during operation to protect them from flying debris, noise and dust.

The work team must be appropriately instructed to be certain they can shut off the machine in an emergency and provide help to the operator.

Be certain the guards are in place and properly secured before the machine is deemed operational.

The grinder must be properly maintained following (at a minimum) the recommended maintenance schedule in this manual and the Engine/Motor manual also supplied with the machine.

Use only genuine DITEQ parts and accessories with this equipment.

Never leave the machine running unattended.

Wear appropriate Personal Protective Equipment (PPE) including safety glasses, boots, head protection and respiratory protection.

Use an effective means to control the dust generated by this machine. The TG8 (aka TEQEdge) is equipped with both a water nozzle and a dry vacuum port & dust skirt.

Gasoline Powered Equipment



The engine exhaust from this product contains chemicals known to the State of California to cause cancer, birth defects or other reproductive harm.



Do not operate gasoline powered equipment without adequate ventilation. Carbon monoxide is an invisible, odorless gas that can cause death if inhaled.



Gasoline is extremely flammable and its vapors can explode if ignited. Store gasoline only in approved containers, in well-ventilated, unoccupied areas, away from sparks, flames or direct sunlight. Do not use gasoline as a cleaning agent. Do not fill the fuel tank while the engine is hot or running, since spilled fuel could ignite if it comes in contact with engine sparks or hot parts.



Parts of the engine can become extremely hot during use. To prevent severe burns, do not touch the engine until after it has cooled.



Never tamper with the governor components or settings on the engine to increase the maximum speed. Engine RPM speeds greater than the engine rating can be dangerous and damage the equipment.

Electrical Powered Equipment



Be certain the equipment is properly grounded and a Ground-Fault Circuit Interrupter (GFCI) is used to protect the operator from Electrical Shock or Electrocutation.



Be certain all electrical cables and connectors are in good condition and correctly sized for both the operating current and the voltage of this equipment.

Adhere to all applicable electrical codes.

Accessories

The TG8 Grinder and Polisher can be fitted with a multitude of accessories to meet the needs of the operator. They are typically classified two different ways, either as to the use of the accessory- (1) Coating Removal, (2) Grinding and (3) Honing/Polishing. They can also be classified by the means of attachment to the machine- (1) Fixed grinding plate, (2) TEQ-Lok Mounted accessories or (3) velcrobacked accessories.

CAUTION

It is very IMPORTANT to understand the proper use and limitations of the accessories before they are used to be certain they are used safely. Some of the velcrobacked accessories have limitations for the MAXIMUM safe operating speed (RPM) before the accessory will fly off and potentially hurt somebody or something.

The TG8 Grinder/Polishers can be used with either 'wet' or 'dry' accessories. It is equipped with a vacuum port and a water hookup. Some accessories are designated as 'wet' only accessories and they must be used 'wet' or damage to the slab surface, accessory and/or equipment will result.

The effectiveness of any diamond accessories can be influenced by the slab surface conditions such as the admixtures, surface hardness, abrasiveness, aggregate size, hardness and depth, the use of topical coatings, curing compounds, sealers, densifiers and/or hardeners, etc... as well as the properties of the machine such as the disc speed (RPM), and contact pressure (the weight of the machine that is pushing on the accessories divided by the contact area of the accessories) and the properties of the diamond accessory itself such as the diamond concentration, diamond quality, the shape of the diamond crystals, size of the diamonds, arrangement/distribution of the diamonds in the accessory, and the shape of the accessory. The effectiveness of the accessory can also be influenced by the use of water to create a slurry. The slurry can be modified with an abrasive additive to the slurry to keep the diamonds open, such as sand, or the consistency of the slurry from the amount of water that is used.

WARNING

Concrete Slurry can create a slip hazard. Post appropriate warnings and minimize the access to the working area to protect bystanders. Wear appropriate footwear and maintain sure footing. Keep the area clean by using a slurry vacuum or other appropriate methods.

Adjusting the dust skirt height for different accessories

Be certain to adjust the height of the dust skirt to match the accessory height. If the skirt is too low, it can prevent the accessory from fully contacting the slab. If the skirt is too high, it might not be effective in retaining/capturing the dust.

The skirt should have between approximately 1/32 to 1/8 inch gap from slab surface.



PCD's

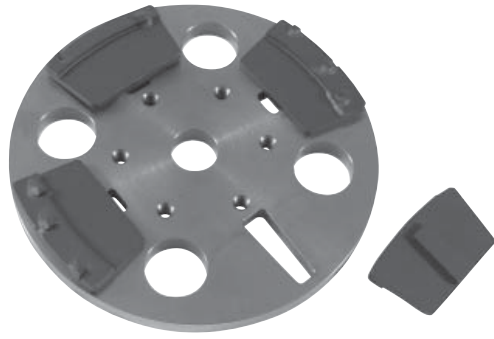

Polycrystalline diamonds (PCD's) are used for removing coatings. They are direction sensitive meaning it matters which direction they are spinning. If they turn the wrong way it will damage the PCD's. They are typically designated as Left (LH) or Right (RH) hand.

Be certain to keep the disc rotationally balanced by matching the accessory on the opposite side of the disc. It is ok to run a mixed set of PCDs as shown in the picture on the left, as long as the 2-chip and the 3-chip PCD's are across from each other.

PCD's can be damaged by hitting obstructions or discontinuities in the slab surface. Be certain to inspect the floor and mark/avoid any areas of the slab that may cause premature damage to the PCD's.

CAUTION

Polycrystalline Diamonds (PCD's) can damage a concrete slab surface. They can be very aggressive, so be careful in how and/or where they are used to prevent damage to the slab surface.



Be certain to keep the guards in place when using the PCD's because flying debris generated by the PCDs can cause injury.



Eye protection **MUST** be worn by anyone near the machine when the machine is in operation.



On variable Speed models, be certain the proper rotation for the PCD is made via the FWD/REV switch.

Fixed Plate Grinding discs

The standard grinding accessories for the TG8 system are the fixed grinding plates. These plates (aka discs) are available in different bonds and with different number of segments (see page 16 for part numbers of some of the more popular discs). The rule of thumb is that soft bonds are for harder slab surfaces to keep the diamonds 'open' and not glazing over, and the harder bonds are used on more abrasive surfaces to give them better life grinding on an abrasive surface that will keep the diamonds exposed ('open'). The discs with fewer segments typically have a shorter life but they have much higher grinding contact pressure because the weight is distributed over fewer segments. The higher contact pressure makes the discs more aggressive.

The new disc should be installed with a new rubber isolator (see page 18 for the proper identification of the rubber disc isolator). The rubber isolator is important to keep the disc resilient and flexible, yet stiff enough to spin true around the center of rotation of the disc. If the isolator is not properly installed or if it loses its stiffness when it heats up, the disc can spin in an oval (egg shaped) pattern and wear unevenly.

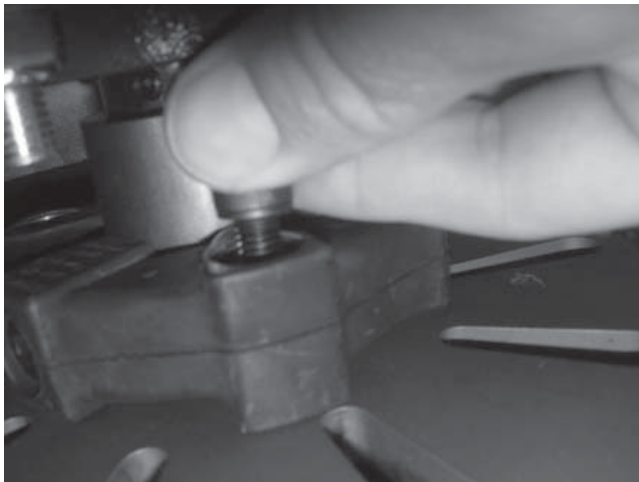
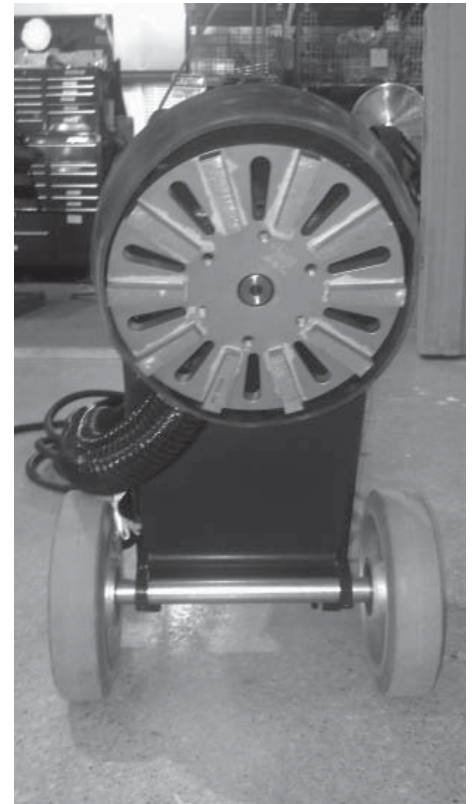

There are two common ways to change the fixed plate grinding discs, either to remove the plate from the coupler while the coupler is on the machine (see picture on Left), or to remove the coupler from the shaft from the machine and take the coupler off the disc on the bench (see picture below).

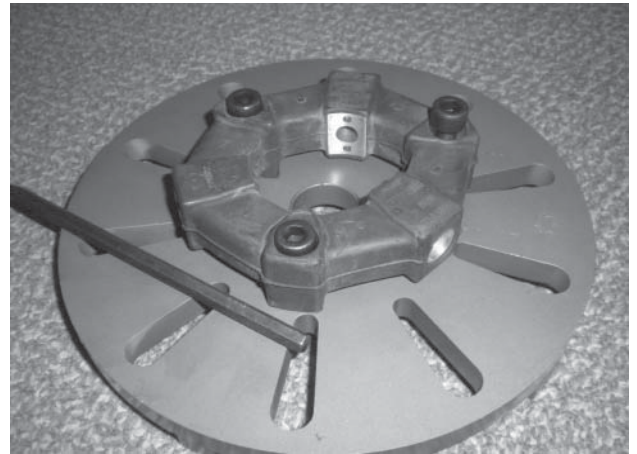

Be certain the seal is properly seated and lubricated with a Petroleum Jelly or axle grease and carefully push the disc over the shaft and seal without unseating the seal from the groove.

TEQ-Lok Accessories

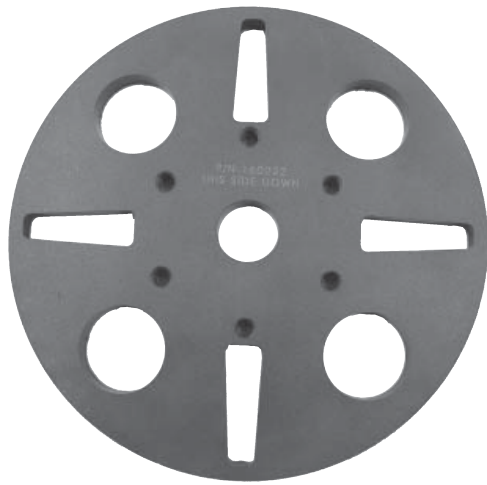

The TEQ-Lok accessories were created to provide a means for the operator to quickly change between different bonds or grits. It is a wedge locking system that is easy to change, but it requires the proper tools and technique.

To Install the new accessory, simply insert it in the mating wedge on the TEQ-Lok driver plate (see picture on Left).

During the grinding process, the centrifugal forces generated on the accessory, lock it in place on the wedge to the point that it is typically not removable without tapping the edge to break loose the friction bond. Be very careful to tap the steel base part and not hit the diamond segment or plastic cup. Use a punch, chisel or screwdriver (see picture below) using a very soft tapping action just enough to break loose the accessory.



Accessories can be very hot after grinding. Burn hazard- Do not touch hot accessories until they have enough time to cool down.



Standard TEQ-Lok full segment accessories are available in different grits and/or bonds. They are used for standard grinding.



The TEQ-Lok Mini Segments provide higher contact pressure for a more aggressive grinding action. The segments are oval shaped to provide the aggressiveness of the rectangular segment with the rounded edges to minimize corner scratches in the slab surface.



CAUTION

TEQ-Lok velcrobacked accessories are available in semimetal and resin bonds. They are a 2" diameter accessory to minimize the inertia of the accessories at higher rotating speeds. They are seated in a plastic cup (ring) to help capture the accessories from breaking from the velcro bond at higher RPM's. NEVER operate the velcrobacked accessories at speeds over 50% without the head fully engaged on the slab surface.



3" Velcrobacked Accessories



CAUTION

3" Velcrobacked accessories can only be used on the slow speed electric machine (p/n - G00018) or the Variable speed model (p/n - G00028) at 50% speed MAXIMUM RPM because the inertia of the heavier 3" accessories can break loose the velcro hold and launch the accessories at the higher RPM's of the Gasoline and Standard Electric models.

DITEQ offers a wide range of 3" velcrobacked accessories including brazed lippage pads, sintered metal, semi-metal and resin pads.

Grinding

The grinding process involves aggressive diamond tools to cut through the slab surface. The more aggressive diamonds leave a scratch pattern that is highly visible. The higher the diamond grit accessory number equates to a smaller physical size of the diamond crystal, and smaller crystals are less aggressive but leave a less visible scratch pattern. Some slab surfaces are treated with cure-n-seals that are invisible to the human eye, or are hard trowelled finishes that are equally difficult to penetrate without using large diamond crystals (ie lower grit sizes like 16G or 24G). Some cure-n-seals melt with high temperatures and coat the diamonds. It is sometimes best to use a little water to create a slurry or to slow the disc speed down on the variable speed models, when grinding these types of cure-n-seals.

To remove the deeper scratches from a previous grit and replace them with a shallower scratch pattern of a higher grit simply double the grit number of the first step (for example, 30G to 60G).

The rotary grinders with the right tooling can be very aggressive and if used improperly can damage the slab surface. Be certain to keep the machine moving at all times while the disc is turning (until the disc comes to a complete stop). To prevent 'corn rows' it is best to move in a slight sweeping motion to blend the newly ground area with the previously ground area.

Polishing

Polishing and Honing a slab surface follows the grinding process. To transition from metal bonds in the grinding process to semimetal or resin bonds is to divide the number of the last grinding step grit by two and start with that grit number accessory semimetal or resin bond (example from 100G metal to 50G resin or semimetal).

The typical progression is to double the grit number to remove the scratches from the previous step.

Semimetals can be treated like a resin bond for the step in the progression process but unlike the resin bonds, they are much more aggressive tools and act much like a metal hybrid.

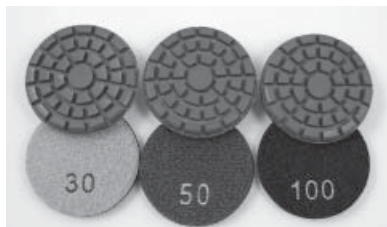

The semimetals (see the picture on the above) can effectively replace the equal grit number (aka grit size or simply grit) of the resin pads (see picture on the right).

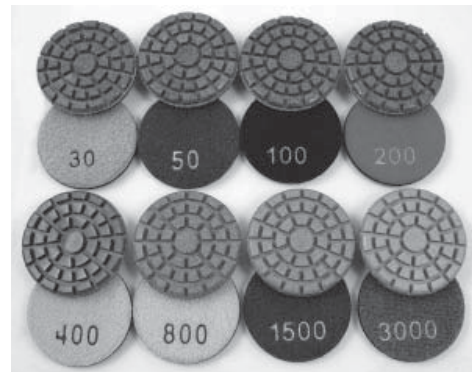

©2012

Typical polished concrete surfaces are treated with a synergistic coating called a densifier applied to the slab surface around the 200G resin step. The densifier soaks into the top surface of the concrete and bonds to the molecular structure in the concrete slab surface and hardens the slab surface. DITEQ offers the DI-Hard Densifier.

Some of the 2" velcrobacked accessories for the TG8 are designated as a WET only or DRY only or WET/DRY. These designations are based mainly on performance and life of the accessory but in some cases the water will keep the accessories cool and if they get too hot they can damage the accessory or the slab surface. Some of the DRY only accessories can have a very short life when used wet. Please be cautious in using the correct accessory for the jobsite conditions.

The final step in the diamond grit progression will define the level of shine. The 400G is a matte shine, 800G a satin, 1500G a gloss and 3000G in a high gloss shine.

The concrete surface can be treated with an oleophobic top sealing semitopical coating to help protect it from stains quickly penetrating and marking the slab before they can be cleaned up in a timely manner. DITEQ offers the DI-Gard for this additional protection. Be certain to follow the directions before applying this coating.

Polished concrete slabs should be maintained and cleaned with a neutral cleaner. DITEQ also offers the daily cleaner and a heavy duty degreaser for use with mop-and-bucket or automatic scrubbing machines. Contact DITEQ for additional information.

SMI Silica and Dust Warning (rev 6-20-06)



Grinding/cutting/drilling of masonry, concrete, metal and other materials can generate dust, mists and fumes containing chemicals known to cause serious or fatal injury or illness, such as respiratory disease, cancer, birth defects or other reproductive harm. If you are unfamiliar with the risks associated with the particular process and/or material being cut or the composition of the tool being used, review the material safety data sheets and/or consult your employer, the manufacturers/suppliers, governmental agencies such as OSHA and NIOSH and other sources on hazardous materials. California and some other authorities, for instance, have published lists of substances known to cause cancer, reproductive toxicity, or other harmful effects.



Control dust, mist and fumes at the source where possible. In this regard, use good work practices and follow the recommendations of the manufacturers/suppliers, OSHA/NIOSH, and occupational and trade associations. Water should be used for dust suppression when wet cutting is feasible. When the hazards from inhalation of dust, mists and fumes cannot be eliminated, the operator and any bystanders should always wear a respirator approved by NIOSH/MSHA for the materials being used.



Grinding/cutting/drilling of masonry, concrete and other materials with silica in their composition may give off dust or mists containing crystalline silica. Silica is a basic component of sand, quartz, brick clay, granite and numerous other minerals and rocks. Repeated and/or substantial inhalation of airborne crystalline silica can cause serious or fatal respiratory diseases, including silicosis. In addition, California and some other authorities have listed respirable crystalline silica as a substance known to cause cancer. When cutting such materials, always follow the respiratory precautions mentioned above.

Hoisting and Lifting



Do not lift overhead. If it falls, it could kill someone and damage property and the machine.

The TEQEdge is a lightweight machine that should be lifted by hand or with the proper rigging material to secure it before lifting it off the ground.

Use blocks under the frame to fully support the frame before strapping it to cargo hold downs.

Electric Motor Models

The single phase electric motor models use a 2 HP induction motor that are standard factory wired for 115V service and can be wired at the factory by request for 220V service using the appropriate NEMA plug for the correct voltage. Consult the factory for the details to match the connector the the plug provided by the machine.

This machine requires a dedicated 20A outlet that is properly grounded. It has an extension cord attached to the machine and additional cords should not be used unless they are properly sized for the application by a qualified electrical service technician or electrician to be certain the machine is supplied with an adequate power to prevent damage to the motor and/or switch.

If using a generator power source, be certain it is properly sized for a 2HP induction motor with enough startup capacity to prevent damage to the motor.

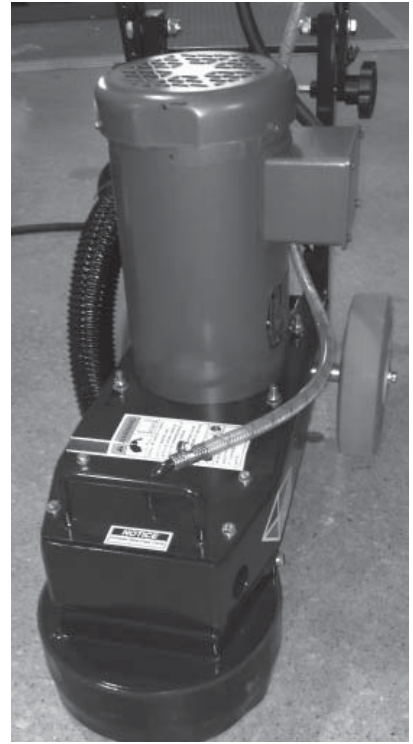

The thermal overload on the motor is located under the motor conduit box (see picture to the left for Leeson and below for Baldor). Be certain the thermal overload and motor are fully cooled before resetting the overload.



Be certain the electrical service to the machine is properly grounded and has a Ground Fault Circuit Interrupt (GFCI) to protect the operator from Electric Shock.



The branch circuit must have overcurrent protection appropriately sized to prevent the branch circuit from overheating and causing an electrical fire.



All machine adjustments and maintenance must be performed only when the machine is turned off and the powercord completely disconnected following the LOTO (Lockout-Tagout) procedures.



Gasoline Engine Models



Do not operate gasoline powered equipment without adequate ventilation. Carbon monoxide is an invisible, odorless gas that can cause death if inhaled.



The Gasoline Powered models have a kickstand option to lift the grinding head off the ground so the engine can be started without the extra load of the disc resisting.

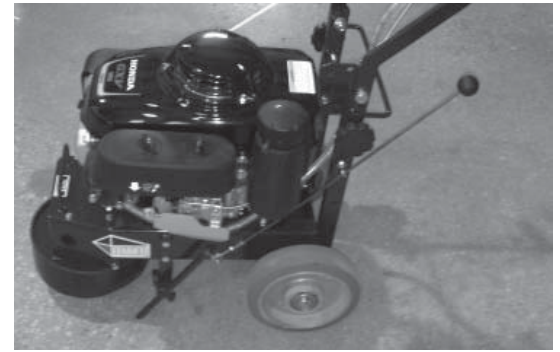

Never leave the engine running unattended.

Read the Engine Operators Manual to familiarize yourself with the Engine controls.

Folding up the machine

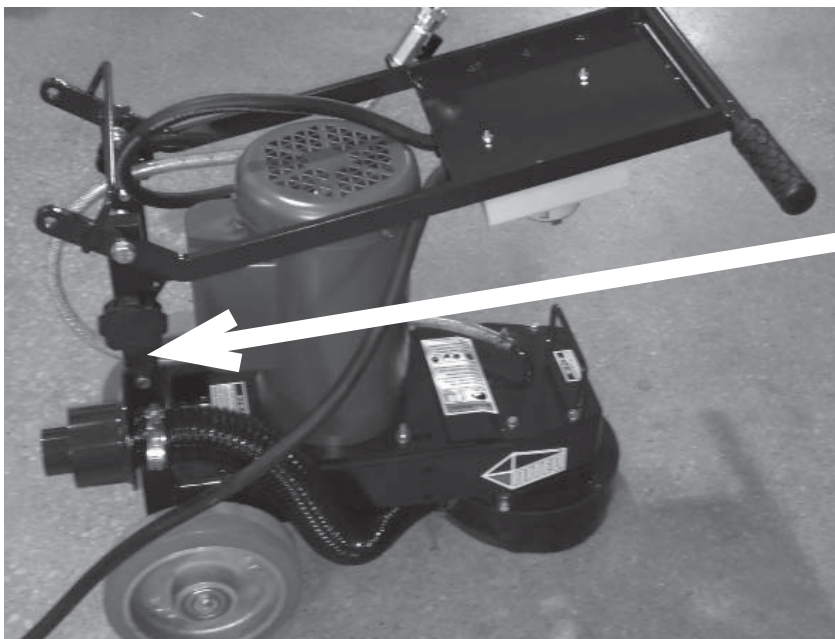

The TG8 handle can be folded up to store as a smaller package size.

Be certain the hardware is completely installed in both the stored state and in the operational state so the handle doesn't collapse and hurt someone or something.

Maintenance Instructions

All repairs should be performed by qualified mechanics in accordance with good shop practices.

Keep the machine clean and in good repair. Use only genuine DITEQ parts and accessories to maximize the life of your investment.

The operator must inspect the machine daily for loose hardware and to be certain all guards and controls are properly installed and in good working condition. If, at any time, the operator feels the machine is not safe, it **MUST** be taken out of service, tagged to keep others from using it and sent to a mechanic for repair.

The machine should be cleaned after every daily use.

Be certain the belts are properly tensioned.

The bearing must be greased every 8 hours of use. Do not overgrease the bearing or it could damage the seals (see picture below for the two grease fitting locations).

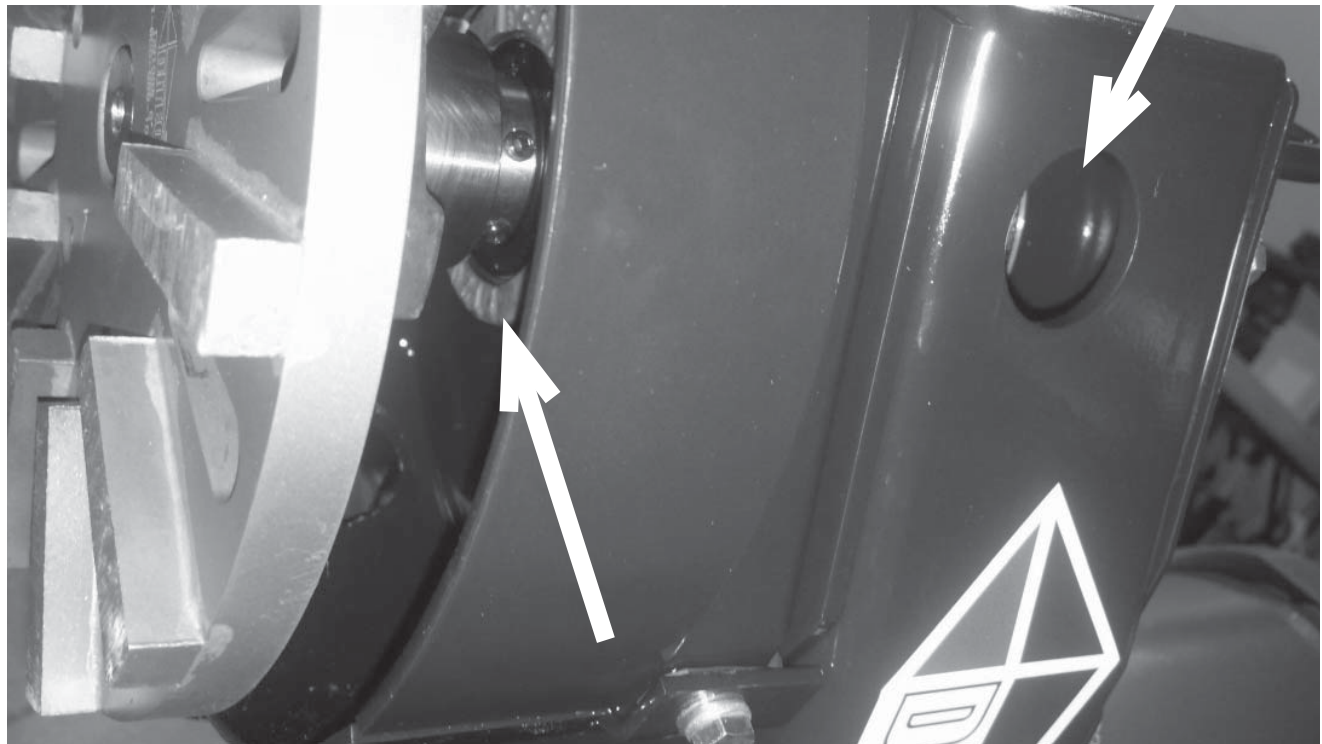

See Engine / Motor Operators Manual

Service the Motor / Engine to the recommended maintenance schedule provided in the respective manual.

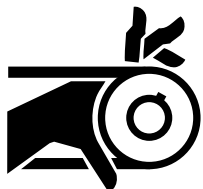

Lock out Power source before performing any maintenance



DO NOT remove any guards or clean the machine without first locking out the power source so the machine can't be started by someone else remotely by reestablishing power (i.e. plugging it back in or turning back on the Circuit Breaker). Death or serious injury can result.

Changing and/or tensioning the belts

Belts must be properly tensioned. If the belts are undertensioned it will reduce the power transmitted from the motor to the grinding head and shorten the life of the belts and pulleys. If the belts are overtensioned it will reduce the life of the belts, bearings, pulleys and motor/engine. Be certain to properly tension the belts.

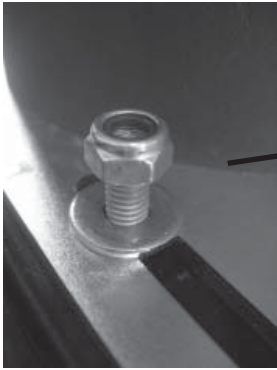

Loosen the motor mounting plate nylon locknuts and remove.

Tilt back motor mounting plate/Motor assy and replace the belts.

Put the motor mounting plate/motor assy back in place

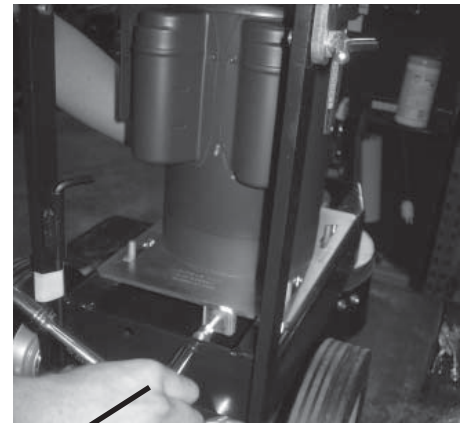
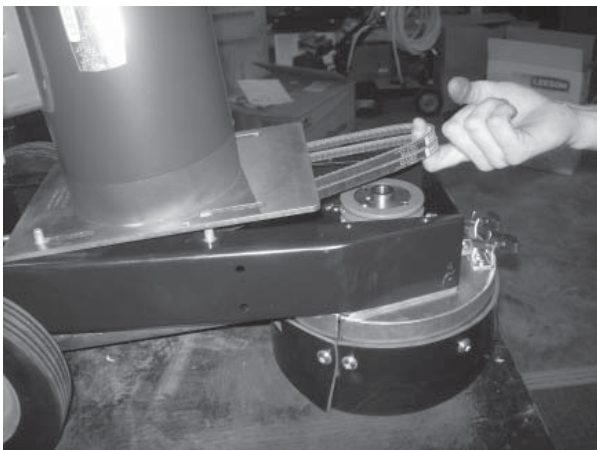
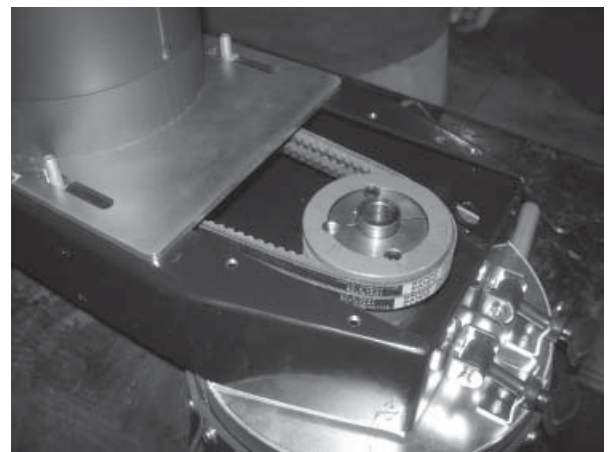
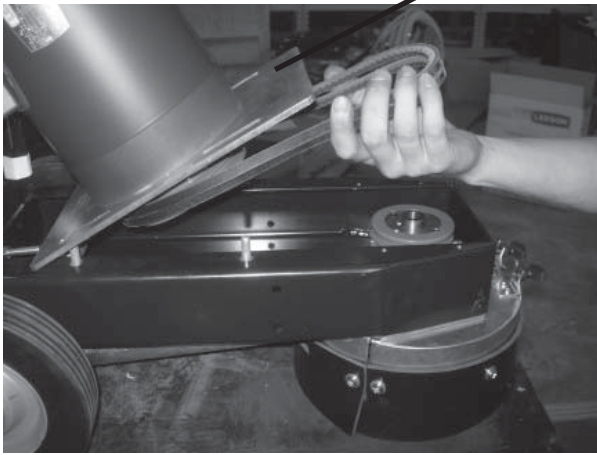

Tighten the belt tensioning bolt until the belts are properly tensioned.

If the pulleys are moved, they will need to be realigned to be certain the belts are running true.

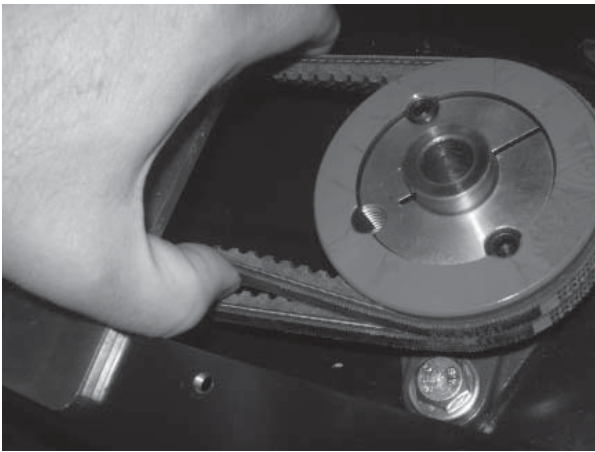

The proper tension of the belts are established by the belt manufacturer. A rule of thumb is that if you can squeeze the belts as shown with a deflection about the thickness of the belt, it is probably close to the proper tension.

Secure the belt tensioning hardware.

Replace the front cover access plate by feeding the water tube through the hole in the shaft.

Tighten all the loose hardware.

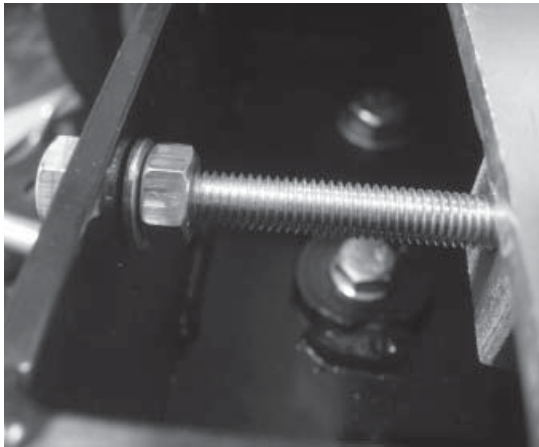

MAIN FRAME GROUPING

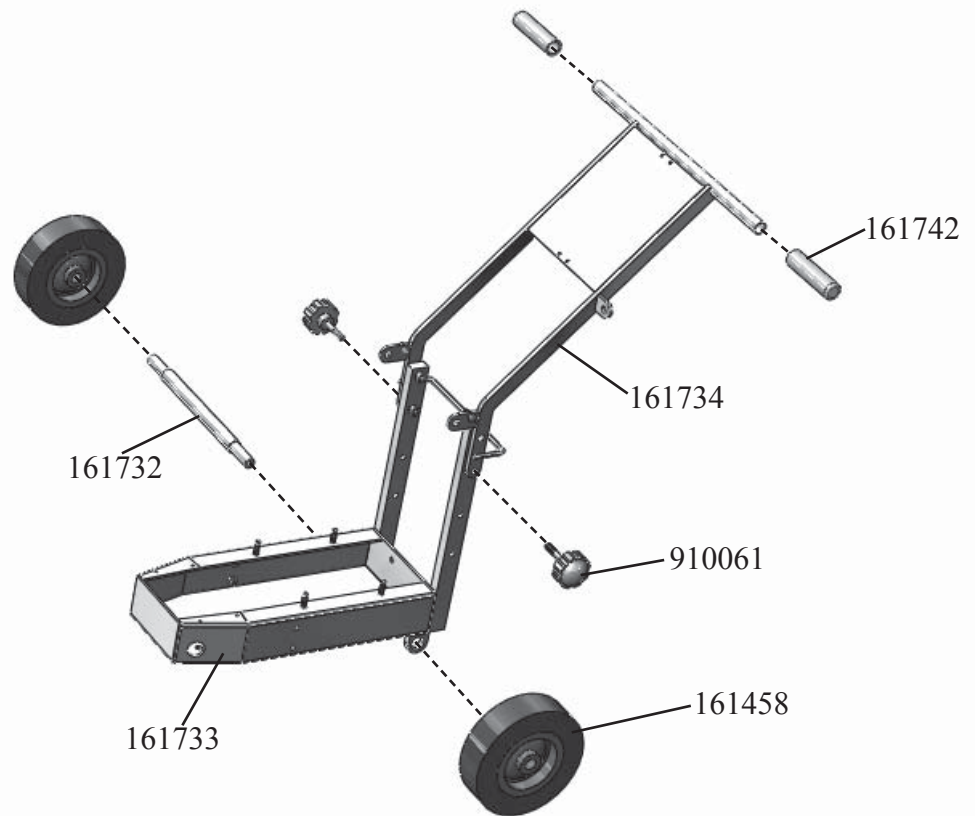

p/n	QTY	DESCRIPTION
100330	1	DECAL KIT
161239	1	OPERATORS MANUAL, 8" TEQEDGE
161129	1	HEX WRENCH, L-, LONGARM, 6mm X 200m
161733	1	TG8 FRAME WELDMENT
161732	1	TG8 REAR AXLE
910065	2	SETSCREW, M5-.8 X 6, CUPPOINT
161458	2	WHEEL 8" X 20mm NONMARKING GRAY
910011	2	SCREW, M8-1.25 X 20, HHCS
910067	2	WASHER M8 FOR TG8 WHEELS
910039	2	WASHER, M8, LOCK SPLIT
161734	1	TG8 HANDLE WELDMENT
910062	2	SCREW, M10-1.5 X 55, HHCS
910004	6	WASHER, M10, FLAT
910033	2	NUT, M10-1.50 LOCK NYLON
910061	2	KNOB, M10-1.5 X 50, 2-3/8" FLUTED
161742	2	TG8 HAND GRIPS

HEAD GROUPING

p/n	QTY	DESCRIPTION
160037	2	BEARING FLANGE - 25MM SST
161222	2	GREASE FITTING, TEQEDGE, 45DEG
910062	2	SCREW, M10-1.5 X 55, HHCS
910004	4	WASHER, M10, FLAT
910033	2	NUT, M10-1.50 LOCK NYLON
160011	1	COUPLING - TEQGRIND
910025	6	SCREW, M8-1.25 X 25, SHCS
161112	1	SHAFT, DISC - TEQEDGE
161113	1	O-RING
160045	1	KEY TG8 SHAFT
160008	1	PULLEY, 2G 3V x 3.35" OD - TAPERLOC
160006	1	HUB TAPERLOCK - 1610 x 25mm
161738	1	TG8 TOP COVER PLATE WELDMENT
910022	4	SCREW M6-1 X 20 HHCS
910002	4	WASHER, M6, LOCK SPLIT
910009	4	WASHER, M6, FLAT
D91003	1	FGG-34 8" GRINDING DISC
160222	1	PLATE, 8" -TEQ-LOK

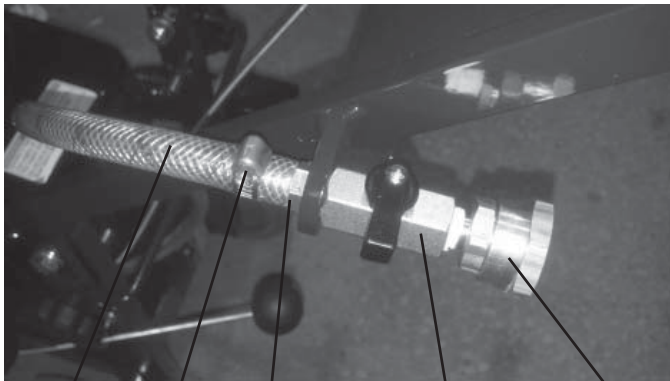
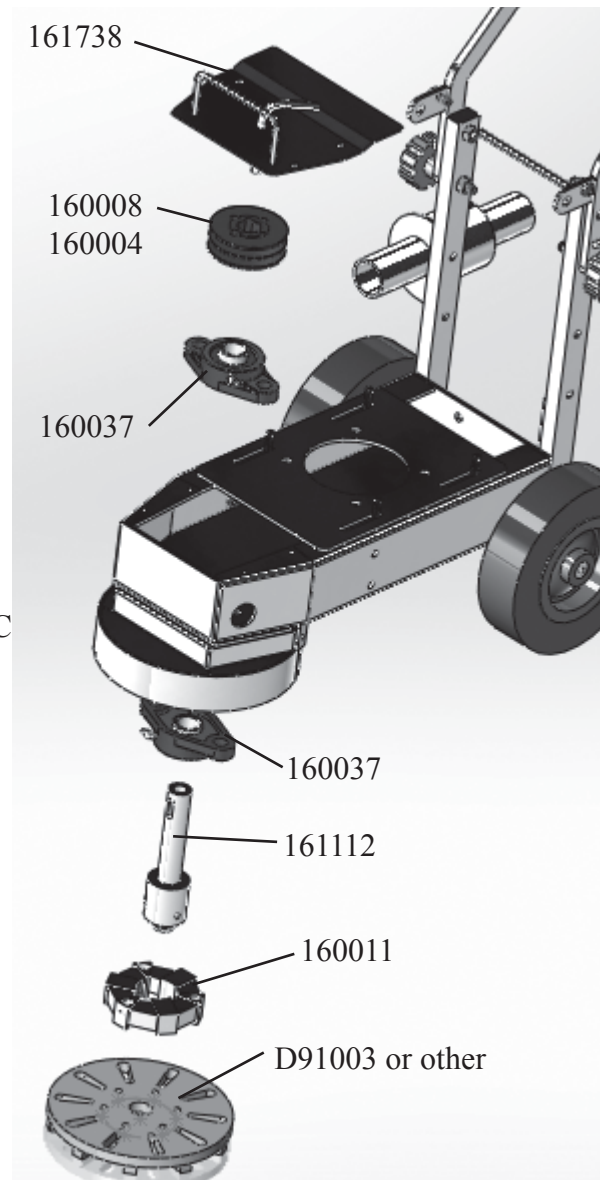

161856
161741
161853
161147
161852

WET KIT GROUPING

161242 WET KIT, TEQEDGE (consists of ...):

- 161856 TG8 WATER HOSE
- 161741 CLAMP, WORMDRIVE HOSE SMALL (QTY-2)
- 161853 HOSE BARB
- 161147 MINI BALL VALVE FOR TEQEDGE
- 161852 1/4NPT-M TO 3/4GHT-F (SWIVEL)

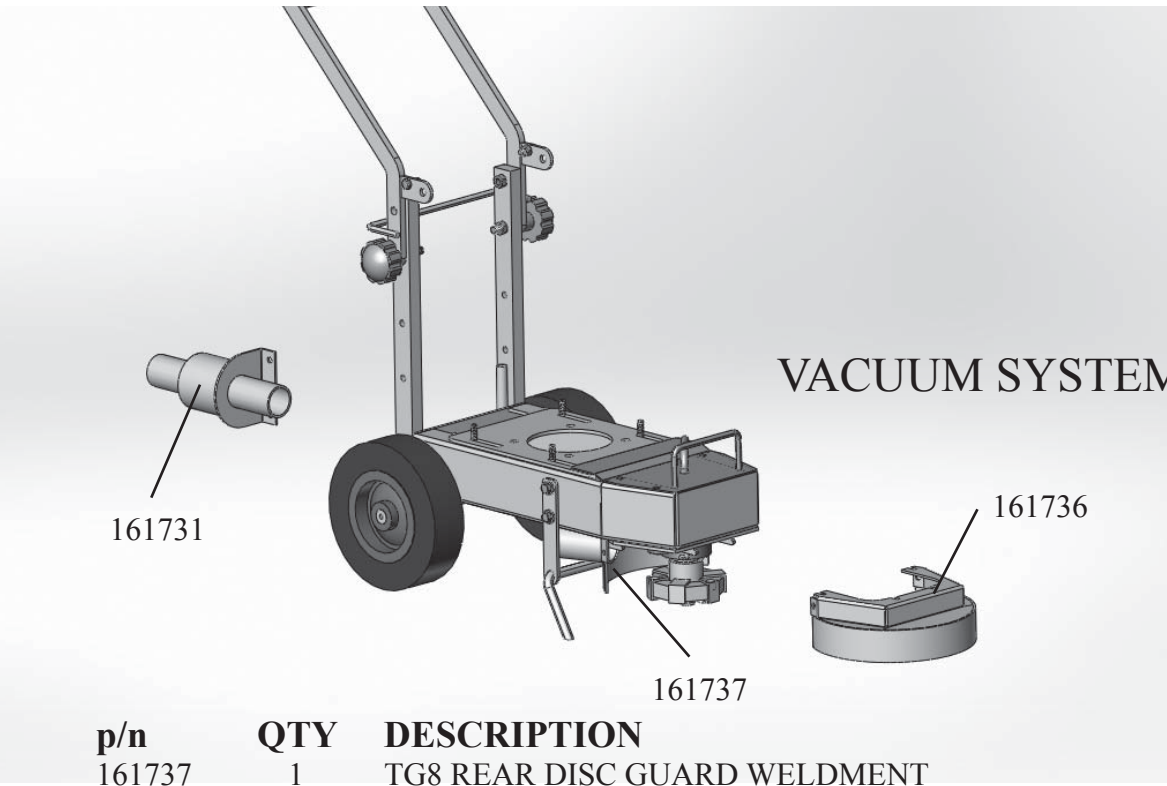

VACUUM SYSTEM GROUPING

p/n	QTY	DESCRIPTION
161737	1	TG8 REAR DISC GUARD WELDMENT
910066	2	NUT CLIPON M6-1 X .8-4MM PANEL
161736	1	TG8 FRONT DISC GUARD WELDMENT
910022	2	SCREW M6-1 X 20 HHCS
910009	2	WASHER, M6, FLAT
910002	2	WASHER, M6, LOCK SPLIT
161731	1	TG8/TG12 VACUUM TUBE BKT
910064	2	SCREW, M8-1.25 X 30, HHCS
910039	2	WASHER, M8, LOCK SPLIT
910031	2	NUT, M8-1.25
161855	1	TG8 VACUUM HOSE
161857	2	CLAMP, WORMDRIVE HOSE LARGE
161790	1	TG8 RUBBER DUST SKIRT

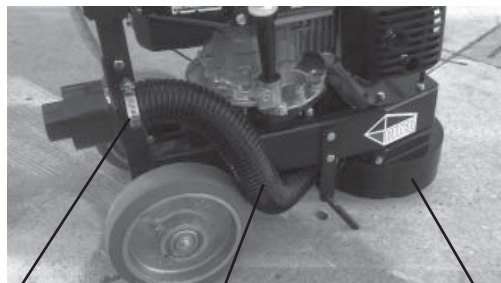

161857 161855 161790

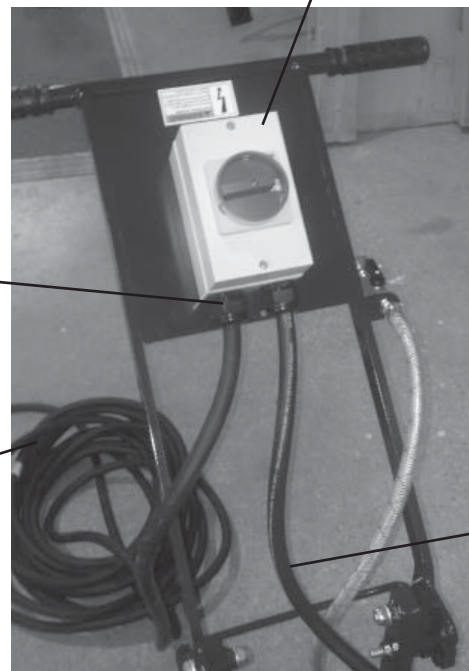

160260 161859 161858

FOR STANDARD ELECTRIC MOTOR, P/N-G00046

p/n	QTY	DESCRIPTION	NOTES
161735	1	TG8 ELEC MOTOR MOUNTING PLATE	
910032	4	NUT, M8-1.25 LOCK NYLON	TO MOUNT PLATE TO FRAME
910039	4	WASHER, M8, LOCK SPLIT	TO MOUNT PLATE TO FRAME
910058	1	SCREW, M8-1.25 X 80, FT HHCS	FOR BELT TENSIONING
910031	1	NUT, M8-1.25	FOR BELT TENSIONING
910037	1	WASHER, M8, FLAT	FOR BELT TENSIONING
160001	1	MOTOR 2HP 1PH 60Hz/4P 115/230V	LEESON OR BALDOR
900036	4	SCREW, 3/8-16 X 3/4, HHCS GR5	
900058	4	WASHER, 3/8, LOCK SPLIT	
161243	1	CORD GRIP, 1/2NPT X .550-.650	CG5. FOR SO CORD 10/3.
160004	1	HUB TAPERLOCK - 1610 X 7/8"	
160007	1	PULLEY 2G 3V x 5" OD - TAPERLOCK	
160009	2	V-BELT 3VX315	
160260	1	SWITCH W/ ENCLOSURE - ROTARY LOCKOUT	
160259	2	STRAIN RELIEF - PG21 THREAD	
900080	2	SCREW, #10-24 X 1/2, MS PANHEAD PHILIPS	
900065	2	WASHER, #10, LOCK SPLIT	
900064	2	NUT, #10-24	
161858	1	TG8 ELEC CORD, SB TO MOTOR	10/3 SO CORD X 34" LONG
161859	1	TG8 ELEC CORD, 50FT	10/3 SO CORD (NO ENDS)
150952	1	PLUG 15A 115V	
150809		PLUG TWIST LOCK - L530P	OPTIONAL- FOR 120V/30A
150954		PLUG TWIST LOCK - L620P	OPTIONAL-FOR 220V/20A
160017		PLUG TWISTLOCK - L520P	OPTIONAL-FOR 120V/20A
160038		THERMAL PROTECTOR (LEESON)	SERVICE PART
160039		CAPACITOR START (LEESON)	SERVICE PART
160040		CAPACITOR RUN (LEESON)	SERVICE PART
161783		THERMAL OVERLOAD, BALDOR TG8	SERVICE PART
161784		START CAPACITOR, BALDOR TG8	SERVICE PART
161785		RUN CAPACITOR, BALDOR TG8	SERVICE PART

FOR VARIABLE SPEED ELECTRIC, P/N-G00047

p/n	QTY	DESCRIPTION	NOTES
161735	1	TG8 ELEC MOTOR MOUNTING PLATE	
910032	4	NUT, M8-1.25 LOCK NYLON	TO MOUNT PLATE TO FRAME
910039	4	WASHER, M8, LOCK SPLIT	TO MOUNT PLATE TO FRAME
910058	1	SCREW, M8-1.25 X 80, FT HHCS	FOR BELT TENSIONING
910031	1	NUT, M8-1.25 FOR BELT TENSIONING	FOR BELT TENSIONING
910037	1	WASHER, M8, FLAT	FOR BELT TENSIONING
161118	1	MOTOR, 2HP 3PH 1750RPM	SYSTEM IS 1PH (MOTOR IS 3PH)
900036	4	SCREW, 3/8-16 X 3/4, HHCS GR5	TO MOUNT ELECTRIC MOTOR
900058	4	WASHER, 3/8, LOCK SPLIT	TO MOUNT ELECTRIC MOTOR
161243	1	CORD GRIP, 1/2NPT X .550-.650	CG5. FOR SO CORD 10/3.
160007	1	PULLEY 2G 3V x 5" OD - TAPERLOCK	
160004	1	HUB TAPERLOCK - 1610 X 7/8"	
160009	2	V-BELT 3VX315	
161119	1	SPEED CONTROLLER, 2HP 120V	1PH POWER TO RUN 3PH MOTOR
161243	2	CORD GRIP, 1/2NPT X .550-.650	CG5. FOR SO CORD 10/3.
900022	4	SCREW, 1/4-20 X 1, HHCS GR5	TO MOUNT KB CONTROLLER
900005	4	NUT, 1/4-20, LOCK NYLON	TO MOUNT KB CONTROLLER
900034	8	WASHER, 1/4, FLAT SAE	TO MOUNT KB CONTROLLER
161858	1	TG8 ELEC CORD, SB TO MOTOR	10/3 SO CORD X 34" LONG
161859	1	TG8 ELEC CORD, 50FT	10/3 SO CORD X 50FT LONG (NO ENDS)
150952	1	PLUG 15A 115V	
161155		SWITCH START - CONTROLLER	SERVICE PART
161629		POTENTIOMETER REPLACEMENT KIT	SERVICE PART
161630		SWITCH FWD-STOP-REV	SERVICE PART

Motor Speed Controller p/n-161119



AC LINE INPUT, MOTOR, AND GROUND CONNECTIONS

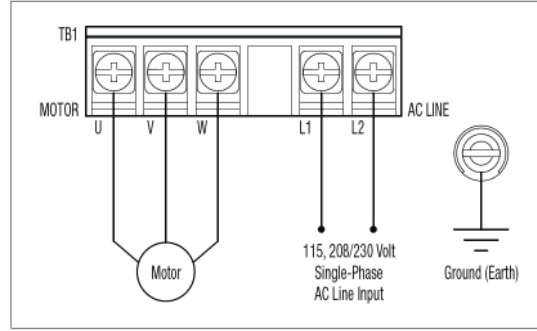

Drive Operating Condition	Flash Rate ¹ and LED Color
Normal Operation	Slow Flash Green
Overload (120% – 160% Full Load)	Steady Red ²
I ² t (Drive Timed Out)	Quick Flash Red ²
Short Circuit	Slow Flash Red
Undervoltage	Quick Flash Red / Yellow ³
Overvoltage	Slow Flash Red / Yellow ³
Stop	Steady Yellow
Stand-By ⁴	Slow Flash Yellow

Notes: 1. Slow Flash = 1 second on and 1 second off. Quick Flash = 0.25 second on and 0.25 second off. 2. When the Overload is removed, before the I²t times out and trips the drive, the "ST" LED will flash green. 3. When the Undervoltage or Overvoltage condition is corrected, the "ST" LED will flash Red / Yellow / Green. 4. Only if the Forward-Stop-Reverse Switch is installed.

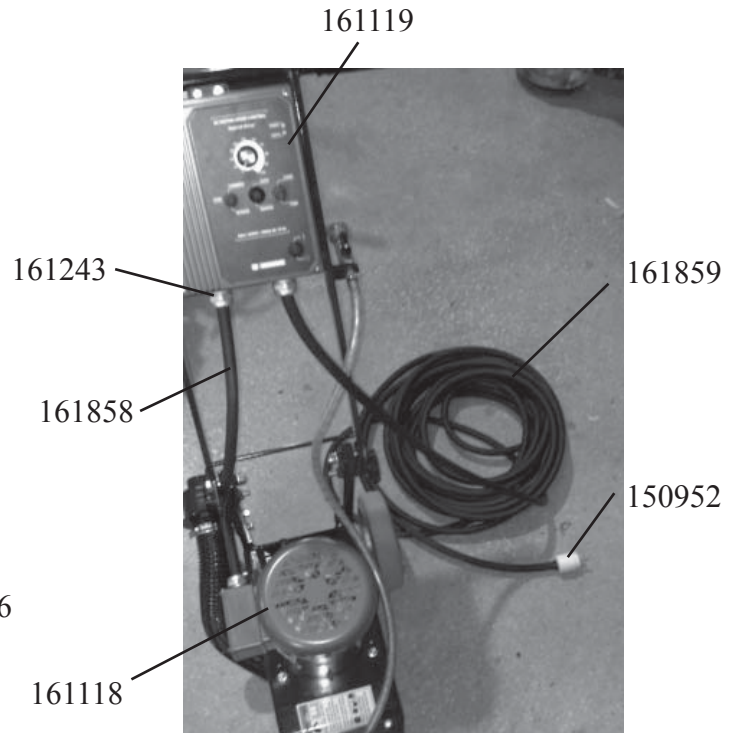
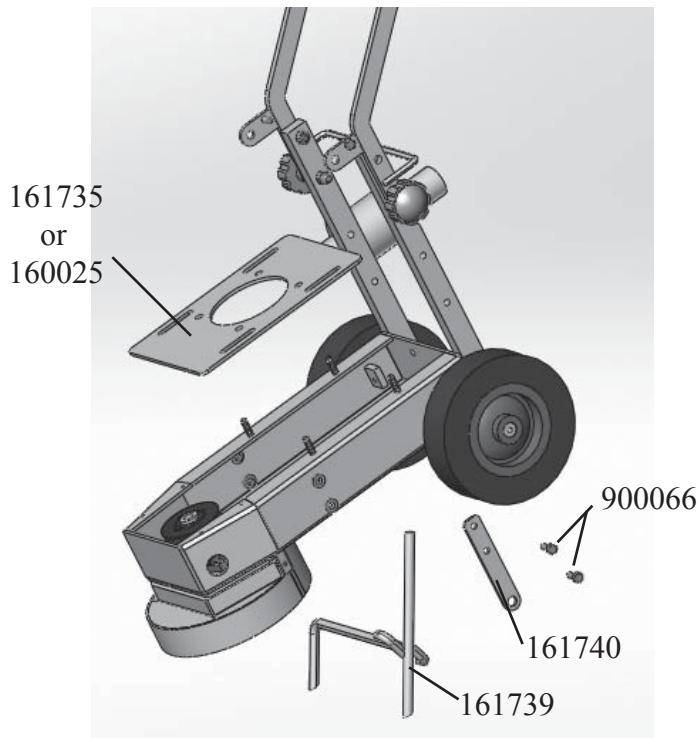

FOR GASOLINE MODEL, P/N-G00048

p/n	QTY	DESCRIPTION	NOTES
160025	1	MOTOR BASE PLATE GAS - TG8	
910032	4	NUT, M8-1.25 LOCK NYLON	TO MOUNT PLATE TO FRAME
910039	4	WASHER, M8, LOCK SPLIT	TO MOUNT PLATE TO FRAME
910058	1	SCREW, M8-1.25 X 80, FT HHCS	FOR BELT TENSIONING
910031	1	NUT, M8-1.25	FOR BELT TENSIONING
910037	1	WASHER, M8, FLAT	FOR BELT TENSIONING
160020	1	ENGINE - 5.5HP HONDA (Subaru also available)	
900123	1	SCREW, 5/16-24 X 7/8, HHCS GR5	TO MOUNT ENGINE TO PLATE
910072	3	SCREW, M6-1 X 45, HHCS	TO MOUNT ENGINE TO PLATE
160061	1	EYE BOLT	TO EXTEND PULL STRING TO HANDLE
900124	2	WASHER, #10, FLAT SAE	TO EXTEND PULL STRING TO HANDLE
900064	2	NUT, #10-24 (QTY-4)	TO EXTEND PULL STRING TO HANDLE
160008	1	PULLEY, 2G 3V x 3.35" OD - TAPERLOCK	
160004	1	HUB TAPERLOCK - 1610 X 7/8"	
100060	2	V-BELT - 3VX280	
160049	1	THROTTLE ASSY - TG8	
900113	2	SCREW, #10-24 X 1/2, SHCS	
900065	2	WASHER, #10, LOCK SPLIT	
161854	1	TG8 KICKSTAND ASSY COMPLETE (CONSISTING OF...)	
		160059 ROD, THREADED (#10-24) (QTY-1)	
		160060 KNOB (QTY-1)	
		160061 EYE BOLT (QTY-2)	
		160062 COUPLING NUT (QTY-1)	
		161251 CLAMP, LOOM (QTY-1)	
		161739 TG8 KICKSTAND GAS ENGINE MODEL (QTY-1)	
		161740 TG8 KICKSTAND MOUNT GAS MODEL (QTY-1)	
		900010 NUT, 5/16-18, LOCK NYLON (QTY-4)	
		900027 SCREW, 1/4-20 X 3/4, HHCS GR5 (QTY-1)	
		900034 WASHER, 1/4, FLAT SAE (QTY-2)	
		900005 NUT, 1/4-20, LOCK NYLON (QTY-1)	
		900064 NUT, #10-24 (QTY-4)	
		900124 WASHER, #10, FLAT SAE (QTY-4)	
		900065 WASHER, #10, LOCK SPLIT (QTY-3)	
		900066 SCREW, 5/16-18 X 1-1/4, HHCS GR5 (QTY-4)	
160323		AIR FILTER -PAPER W/ FOAM 5.5V HOND	SERVICE PART

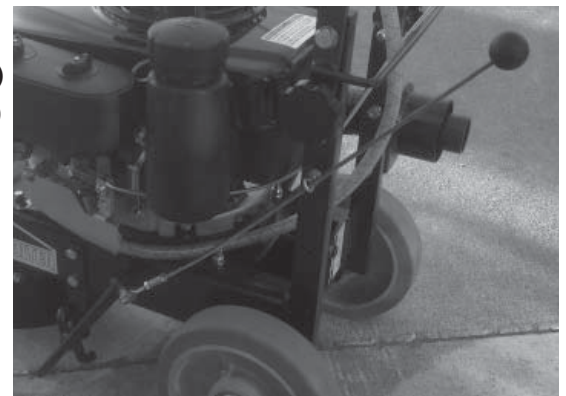

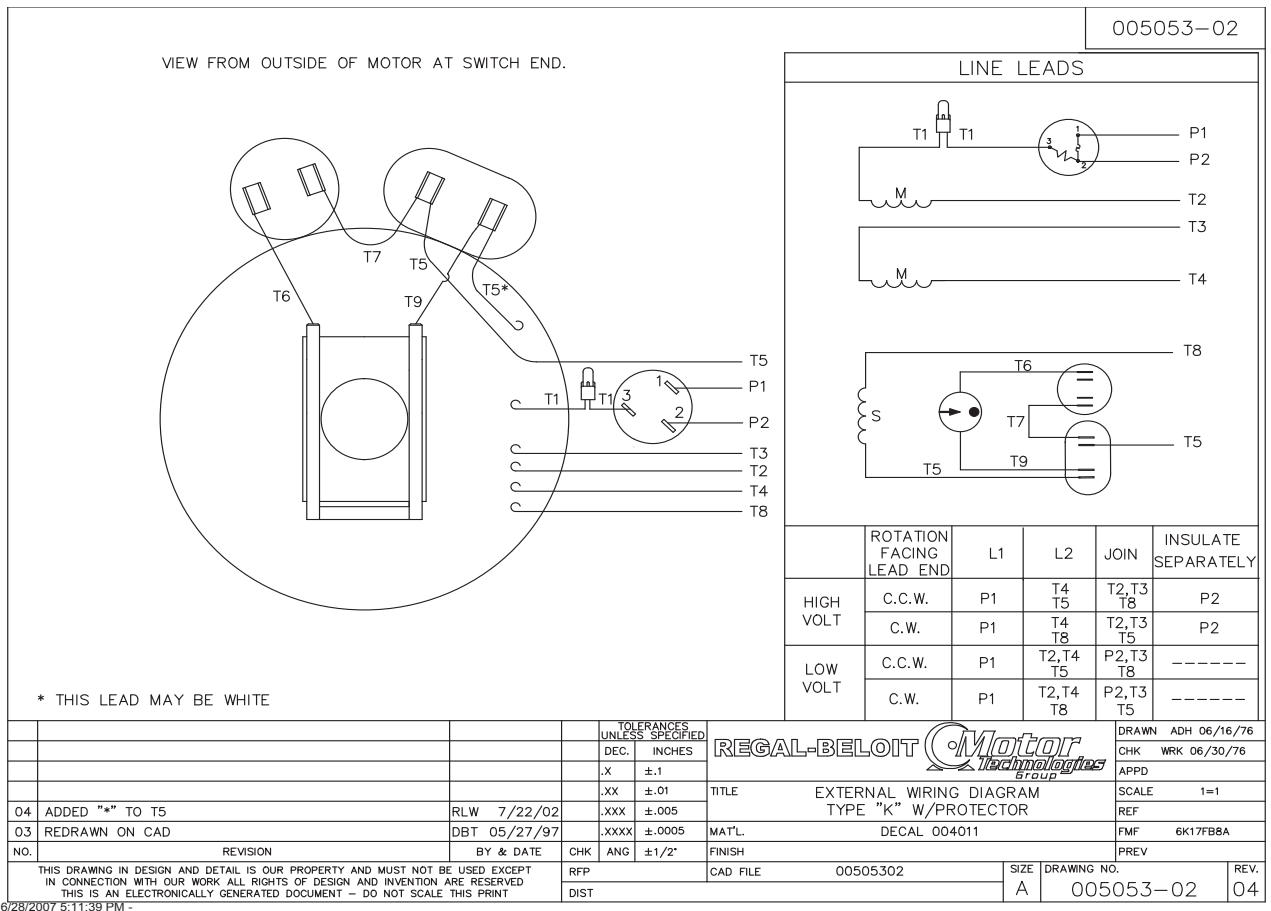
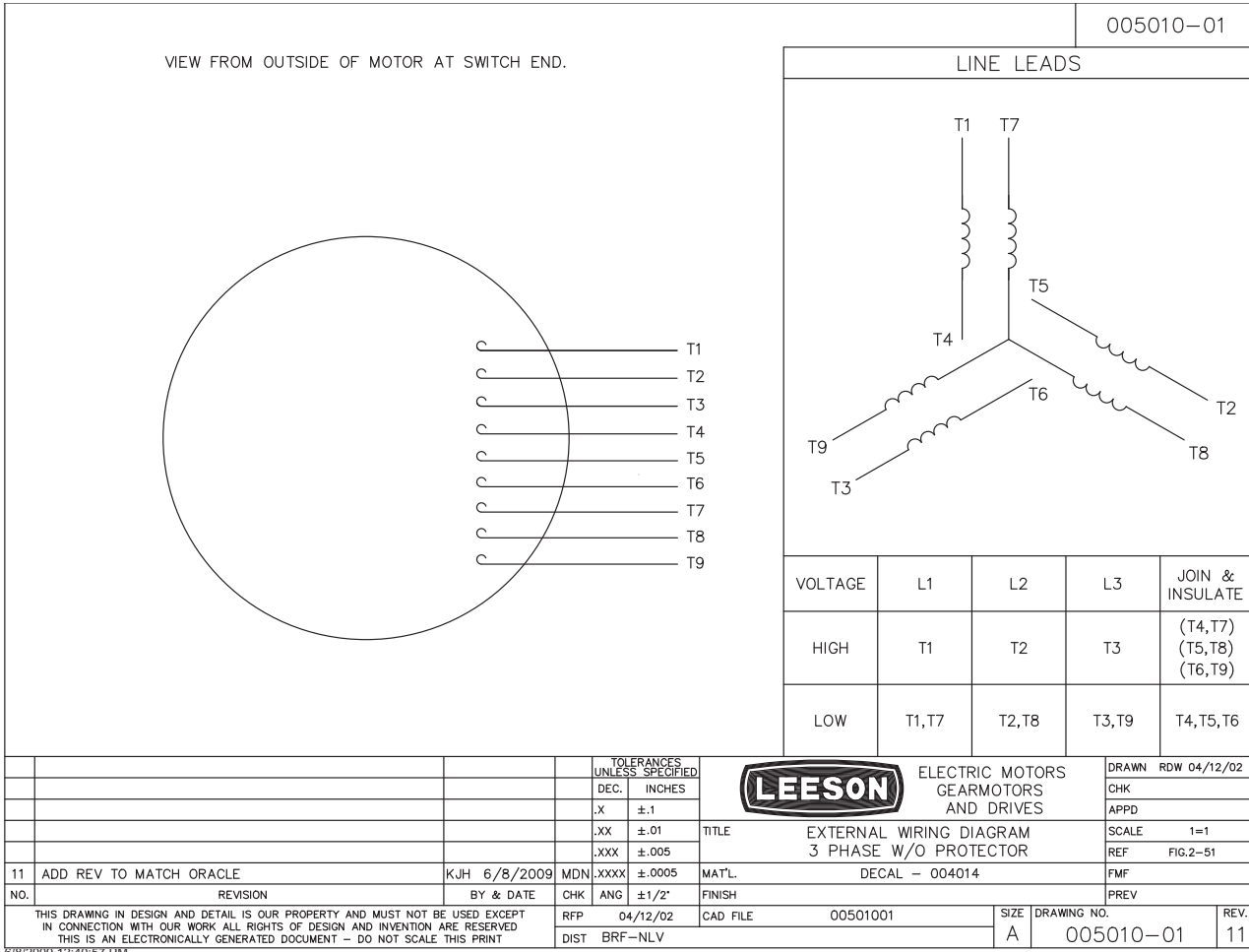

LIMITED WARRANTY FOR NEW DITEQ EQUIPMENT

GENERAL PROVISIONS – The warranties described below are provided by DITEQ Corporation (“DITEQ”) to the original purchasers of new DITEQ Equipment from DITEQ or authorized DITEQ dealers. Under these warranties, DITEQ will repair or replace, at its option, any covered part which is found to be defective in material or workmanship during the applicable warranty term. Warranty service must be performed by DITEQ or a dealer or service center authorized by DITEQ to sell and/or service the type of product involved, which will use only new or remanufactured parts or components furnished by DITEQ. Warranty service will be performed without charge to the purchaser for parts or labor. The purchaser will be responsible, however for any service call and/or transportation and/or freight of product to and from DITEQ’s, the dealer’s or service center’s place of business, for any premium charged for overtime labor requested by the purchaser, and for any service and/or Maintenance not directly related to any defect covered under the warranties below.

WHAT IS WARRANTED – All parts of any new DITEQ Equipment are warranted for the number of Months specified below. Component manufacturers offer separate warranties and warranty terms as stated below. Warranty statements required by law covering engine emission-related parts and components are found in the engine operating manual delivered with the machine. Each warranty term begins on the date of product delivery to the purchaser.

TG8 Grinder 24 Months

KB Controller 12 Months

Leeson Motors 12 Months

Subaru Robin Engines 24 Months

Honda Engines 12 Months

WHAT IS NOT WARRANTED – DITEQ IS NOT RESPONSIBLE FOR THE FOLLOWING:

(1) Used products; (2) Any product that has been modified in ways not approved by DITEQ; (3) Depreciation or damage caused by normal wear, lack of reasonable and proper maintenance, failure to follow operating instructions, misuse, lack of proper protection during storage, transporting or accident; (4) Normal maintenance parts and service.

SECURING WARRANTY SERVICE – To secure warranty service, the purchaser must (1) report the

Product defect to DITEQ, an authorized dealer or an authorized service center and request repair within the applicable warranty term, (2) present evidence of the warranty start date, and (3) make the product available to DITEQ, the dealer or service center within a reasonable period of time.

LIMITATIONS OF IMPLIED WARRANTIES AND OTHER REMEDIES – To the extent permitted by law, neither DITEQ nor any company affiliated with it makes any warranties, representations or promises as to the quality, performance or freedom from defect of the equipment covered by this warranty.

IMPLIED WARRANTIES OF MERCHANTABILITY AND FITNESS FOR A PARTICULAR PURPOSE, TO THE EXTENT APPLICABLE, SHALL BE LIMITED IN DURATION TO THE APPLICABLE PERIOD OF WARRANTY SET FORTH ON THIS PAGE. THE PURCHASER’S ONLY REMEDIES IN CONNECTION WITH THE BREACH OR PERFORMANCE OF ANY WARRANTY ON THE DITEQ EQUIPMENT ARE THOSE SET FORTH ON THIS PAGE. IN NO EVENT WILL THE DEALER, DITEQ OR ANY COMPANY AFFILIATED WITH DITEQ BE LIABLE FOR INCIDENTAL OR CONSEQUENTIAL DAMAGES. (Note: Some states do not allow limitations on how long an implied warranty lasts or the exclusion or limitation of incidental or consequential damages so the above limitations and exclusions may not apply to you.) This warranty gives you specific legal rights, and you may also have other rights which vary from state to state.

NO DEALER WARRANTY- THE SELLING DEALER MAKES NO WARRANTY OF ITS OWN AND THE DEALER HAS NO AUTHORITY TO MAKE ANY REPRESENTATION OR PROMISE ON BEHALF OF DITEQ, OR TO MODIFY THE TERMS OR LIMITATIONS OF THIS WARRANTY IN ANY WAY.

If further information is desired, contact DITEQ.

DITEQ Corporation

9876 Pflumm Road

Lenexa, KS 66215

www.DITEQ.com

Toll-Free Phone: 866-688-1032

Toll-Free Fax: 877-220-4777